



# SGL50

## Bezreduktorowa wciągarka linowa

Zasilanie : 380V  
 Przełożenie : 2 : 1  
 PZD140B Hamulec : DC110V 2×0.89A  
 PZD140 Hamulec : DC110V 4×0.69A  
 Przybliżona masa własna : 1120kg  
 Maksymalne statyczne obciążenie wału : 14000kg

Nr kat.	Udźwig (kg)	Prędkość (m/s)	Średnica koła (mm)	Liny (mm)	Średnica Double Roping (mm)	Prąd (A)	Moment Obr.(Nm)	Obroty (rpm)	Częstość (Hz)	Moc (kW)	Bieguny	Rating	INS.Class	IP Code
SGL50-103P0	1000	3.0	Φ560	10xΦ13x18	YES	42.8	955	205	34.2	20.5	20	S5-50%	F	IP21
SGL50-104P0	1000	4.0	Φ560	10xΦ13x18	YES	56.5	955	273	45.5	27.3	20	S5-50%	F	IP21
SGL50-123P0	1250	3.0	Φ560	10xΦ13x18	YES	53.3	1190	205	34.2	25.5	20	S5-50%	F	IP21
SGL50-124P0	1250	4.0	Φ560	10xΦ13x18	YES	72	1190	273	45.5	34	20	S5-50%	F	IP21
SGL50-133P0	1350	3.0	Φ560	10xΦ13x18	YES	57.2	1290	205	34.2	27.7	20	S5-50%	F	IP21
SGL50-134P0	1350	4.0	Φ560	10xΦ13x18	YES	75.5	1290	273	45.5	36.9	20	S5-50%	F	IP21
SGL50-162P5	1600	2.5	Φ560	12xΦ13x18	YES	56.5	1525	171	28.5	27.3	20	S5-50%	F	IP21
SGL50-163P0	1600	3.0	Φ560	12xΦ13x18	YES	69.5	1525	205	34.2	32.7	20	S5-50%	F	IP21
SGL50-164P0	1600	4.0	Φ560	12xΦ13x18	YES	93	1525	273	45.5	43.6	20	S5-50%	F	IP21
SGL50-202P5	2000	2.5	Φ560	12xΦ13x18	YES	72	1910	171	28.5	34.2	20	S5-50%	F	IP21
SGL50-203P0	2000	3.0	Φ560	12xΦ13x18	YES	90	1910	205	34.2	41	20	S5-50%	F	IP21
SGL50-204P0	2000	4.0	Φ560	12xΦ13x18	YES	120	1910	273	45.5	54.3	20	S5-50%	F	IP21

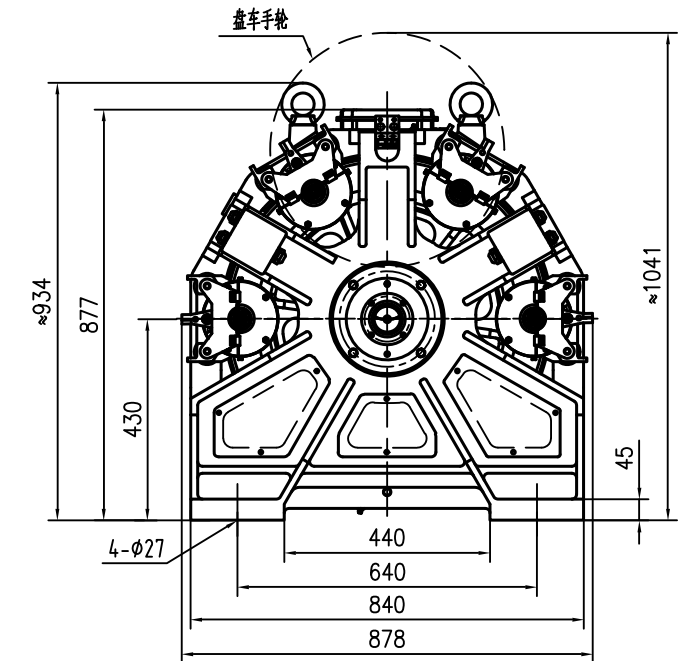
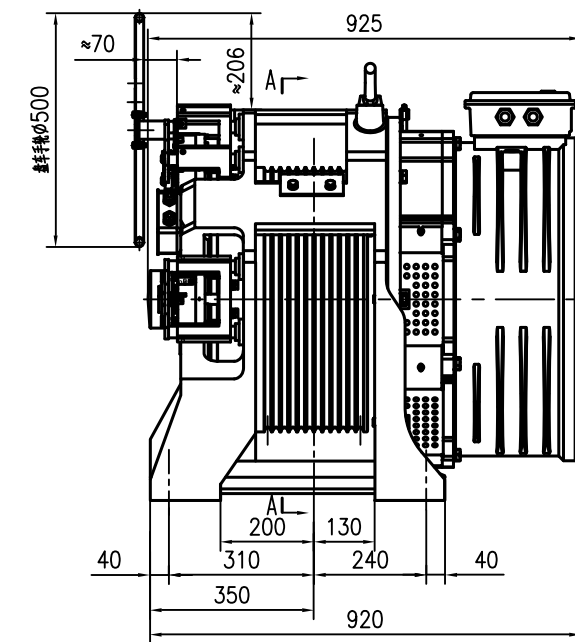

**Uwagi:**

- 1.Maszyna ma możliwość użycia koła do obrotu wału.
- 2.Hamulce:PZD140B dla 1000-1350kg;PZD140 dla 1600-2000kg.

