



► SGL40

Bezreduktorowa wciągarka linowa

Zasilanie : 380V

Maksymalne statyczne obciążenie wału : 8000kg

FZD15 Hamulec : DC110V 2x2.2A

Przybliżona masa własna : 910kg

Nr kat.	Udźwig (kg)	Prędkość (m/s)	Średnica koła(mm)	Liny	Prąd (A)	Moment Obr.(Nm) (rpm)	Częstość (Hz)	Moc (kW)	Bieguny	Rating	INS.Class	IP Code	Przełożenie
SGL40-201P0	2000	1.0	Φ520	6xΦ13x20	29.2	1735 73	19.5	13.3	32	S5(40%)	F	IP41	2:1
SGL40-201P7	2000	1.75	Φ520	6xΦ13x20	48.7	1735 128	34.1	23.3	32	S5(40%)	F	IP41	2:1
SGL40-202P0	2000	2.0	Φ520	6xΦ13x20	54.6	1735 147	39.2	26.7	32	S5(40%)	F	IP41	2:1
SGL40-251P0	2500	1.0	Φ520	7xΦ13x20	35.7	2170 73	19.5	16.6	32	S5(40%)	F	IP41	2:1
SGL40-251P7	2500	1.75	Φ520	7xΦ13x20	59.8	2170 128	34.1	29.1	32	S5(40%)	F	IP41	2:1
SGL40-252P0	2500	2.0	Φ520	7xΦ13x20	68.3	2170 147	39.2	33.4	32	S5(40%)	F	IP41	2:1
SGL40-121P0-1	1250	1.0	Φ485	8xΦ12x18	19.7	1925 40	10.7	8.1	32	S5(40%)	F	IP41	1:1
SGL40-121P6-1	1250	1.6	Φ485	8xΦ12x18	28.2	1925 63	16.8	12.7	32	S5(40%)	F	IP41	1:1
SGL40-121P7-1	1250	1.75	Φ485	8xΦ12x18	30.4	1925 69	18.4	13.9	32	S5(40%)	F	IP41	1:1
SGL40-122P0-1	1250	2.0	Φ485	8xΦ12x18	35.2	1925 79	21.1	15.9	32	S5(40%)	F	IP41	1:1
SGL40-131P0-1	1350	1.0	Φ485	8xΦ12x18	21.3	2080 40	10.7	8.7	32	S5(40%)	F	IP41	1:1
SGL40-131P6-1	1350	1.6	Φ485	8xΦ12x18	30.5	2080 63	16.8	13.7	32	S5(40%)	F	IP41	1:1
SGL40-131P7-1	1350	1.75	Φ485	8xΦ12x18	32.8	2080 69	18.4	15.0	32	S5(40%)	F	IP41	1:1
SGL40-132P0-1	1350	2.0	Φ485	8xΦ12x18	38	2080 79	21.1	17.2	32	S5(40%)	F	IP41	1:1

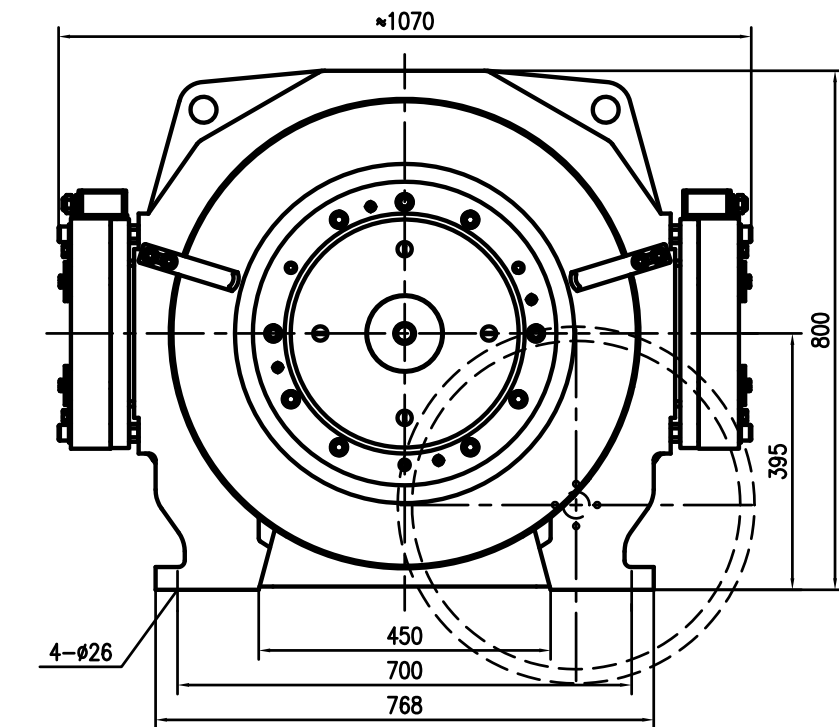
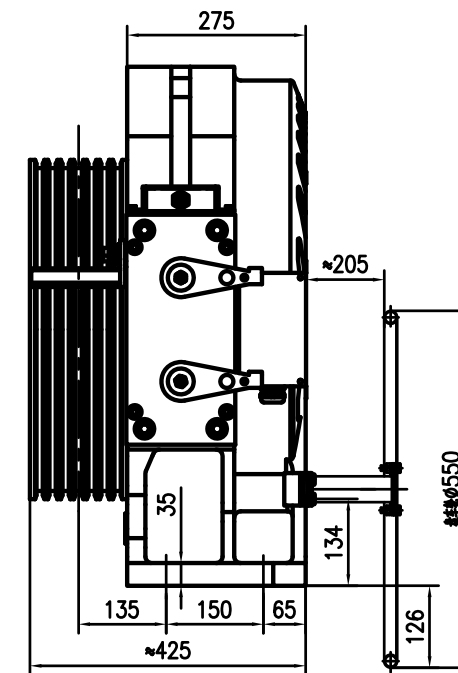

Uwagi:

Maszyna może być wyposażona w zdalne zwalnianie hamulca (4m)