



SGL31

Bezreduktorowa wciągarka linowa

Zasilanie : 380V

Przełożenie : 2:1/4:1

FZD14 Hamulec : DC110V 2x2A

Przybliżona masa własna 580kg

Maksymalne statyczne obciążenie wału : 6000kg

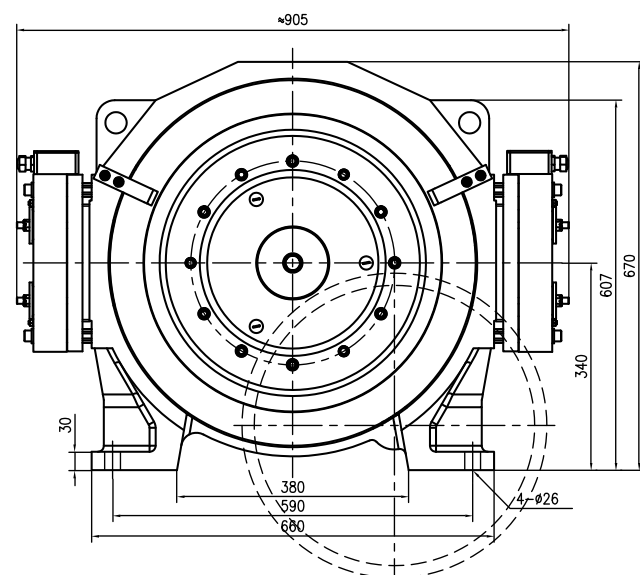
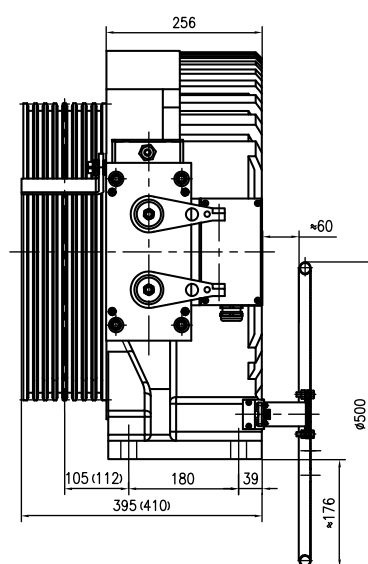

Uwagi:

1. Maszyna może być wyposażona w zdalne zwalnianie hamulca (4m)
2. Wymiary w nawiasach dotyczą wciągarki z kołem ciernym $\Phi 410$ mm.
3. Stosunek przeciwwag dla 9 oznaczonych maszyn * nie może być mniejszy niż 0,47.

Nr kat.	Udźwig (kg)	Prędkość (m/s)	Średnica koła(mm)	Liny	Prąd (A)	Moment Obr.(Nm)	Obroty (rpm)	Częstość (Hz)	Moc (kW)	Bieguny Rating	INS.Class	IP Code	Przełożenie
SGL31-111P0	1150	1	Φ485	6×Φ10×16	17.4	910	79	21.1	7.5	32	S5(40%)	F	IP41 2:1
SGL31-111P5	1150	1.5	Φ485	6×Φ10×16	26.5	910	118	31.5	11.2	32	S5(40%)	F	IP41 2:1
SGL31-111P6	1150	1.6	Φ485	6×Φ10×16	26.5	910	126	33.6	12.0	32	S5(40%)	F	IP41 2:1
SGL31-111P7	1150	1.75	Φ485	6×Φ10×16	29.2	910	138	36.8	13.1	32	S5(40%)	F	IP41 2:1
SGL31-112P0	1150	2	Φ485	6×Φ10×16	33.3	910	158	42.1	15.1	32	S5(40%)	F	IP41 2:1
SGL31-112P5	1150	2.5	Φ485	6×Φ10×16	41.2	910	197	52.5	18.8	32	S5(40%)	F	IP41 2:1
SGL31-121P0	1250	1	Φ485	6×Φ10×16	18.9	990	79	21.1	8.2	32	S5(40%)	F	IP41 2:1
SGL31-121P5	1250	1.5	Φ485	6×Φ10×16	28.8	990	118	31.5	12.2	32	S5(40%)	F	IP41 2:1
SGL31-121P6	1250	1.6	Φ485	6×Φ10×16	28.8	990	126	33.6	13.1	32	S5(40%)	F	IP41 2:1
SGL31-121P7	1250	1.75	Φ485	6×Φ10×16	31.8	990	138	36.8	14.3	32	S5(40%)	F	IP41 2:1
SGL31-122P0	1250	2	Φ485	6×Φ10×16	36.2	990	158	42.1	16.4	32	S5(40%)	F	IP41 2:1
SGL31-122P5	1250	2.5	Φ485	6×Φ10×16	44.8	990	197	52.5	20.4	32	S5(40%)	F	IP41 2:1
SGL31-131P0	1350	1.0	Φ485	7×Φ10×16	19.3	1070	79	21.1	8.9	32	S5(40%)	F	IP41 2:1
SGL31-131P5	1350	1.5	Φ485	7×Φ10×16	29.5	1070	118	31.5	13.2	32	S5(40%)	F	IP41 2:1
SGL31-131P6	1350	1.6	Φ485	7×Φ10×16	29.5	1070	126	33.6	14.1	32	S5(40%)	F	IP41 2:1
SGL31-131P7	1350	1.75	Φ485	7×Φ10×16	32.2	1070	138	36.8	15.5	32	S5(40%)	F	IP41 2:1
SGL31-132P0	1350	2.0	Φ485	7×Φ10×16	37.0	1070	158	42.1	17.7	32	S5(40%)	F	IP41 2:1
SGL31-132P5	1350	2.5	Φ485	7×Φ10×16	45.8	1070	197	52.5	22.1	32	S5(40%)	F	IP41 2:1
SGL31-161P0	1600	1.0	Φ485	8×Φ10×16	22.8	1270	79	21.1	10.5	32	S5(40%)	F	IP41 2:1
SGL31-161P5	1600	1.5	Φ485	8×Φ10×16	35.6	1270	118	31.5	15.7	32	S5(40%)	F	IP41 2:1
SGL31-161P6	1600	1.6	Φ485	8×Φ10×16	35.6	1270	126	33.6	16.8	32	S5(40%)	F	IP41 2:1
SGL31-161P7	1600	1.75	Φ485	8×Φ10×16	38.7	1270	138	36.8	18.4	32	S5(40%)	F	IP41 2:1
SGL31-162P0	1600	2.0	Φ485	8×Φ10×16	44.5	1270	158	42.1	21.0	32	S5(40%)	F	IP41 2:1
SGL31-162P5	1600	2.5	Φ485	8×Φ10×16	55.7	1270	197	52.5	26.2	32	S5(40%)	F	IP41 2:1
SGL31-131P0A	1350	1	Φ410	7×Φ10×16	21.2	910	93	24.8	8.9	32	S5(40%)	F	IP41 2:1
SGL31-131P5A	1350	1.5	Φ410	7×Φ10×16	31.5	910	140	37.3	13.3	32	S5(40%)	F	IP41 2:1
SGL31-131P6A	1350	1.6	Φ410	7×Φ10×16	31.5	910	149	39.7	14.2	32	S5(40%)	F	IP41 2:1
SGL31-131P7A	1350	1.75	Φ410	7×Φ10×16	35.5	910	163	43.5	15.5	32	S5(40%)	F	IP41 2:1
SGL31-132P0A	1350	2	Φ410	7×Φ10×16	38.1	910	186	49.6	17.7	32	S5(40%)	F	IP41 2:1
SGL31-161P0A	1600	1.0	Φ410	8×Φ10×16	24.3	1070	93	24.8	10.4	32	S5(40%)	F	IP41 2:1
SGL31-161P5A	1600	1.5	Φ410	8×Φ10×16	36.5	1070	140	37.3	15.7	32	S5(40%)	F	IP41 2:1
SGL31-161P6A	1600	1.6	Φ410	8×Φ10×16	36.5	1070	149	39.7	16.7	32	S5(40%)	F	IP41 2:1
SGL31-161P7A	1600	1.75	Φ410	8×Φ10×16	39.8	1070	163	43.5	18.3	32	S5(40%)	F	IP41 2:1
SGL31-162P0A	1600	2.0	Φ410	8×Φ10×16	45.5	1070	186	49.6	20.8	32	S5(40%)	F	IP41 2:1
* SGL31-201P0A	2000	1.0	Φ410	9×Φ10×16	28.4	1270	93	24.8	12.4	32	S5(40%)	F	IP41 2:1
* SGL31-201P5A	2000	1.5	Φ410	9×Φ10×16	44.1	1270	140	37.3	18.6	32	S5(40%)	F	IP41 2:1
* SGL31-201P6A	2000	1.6	Φ410	9×Φ10×16	44.1	1270	149	39.7	19.8	32	S5(40%)	F	IP41 2:1
* SGL31-201P7A	2000	1.75	Φ410	9×Φ10×16	47.3	1270	163	43.5	21.7	32	S5(40%)	F	IP41 2:1
* SGL31-202P0A	2000	2.0	Φ410	9×Φ10×16	54.4	1270	186	49.6	24.7	32	S5(40%)	F	IP41 2:1
* SGL31-300P5-4	3000	0.5	Φ485	8×Φ10×16	20.5	1113	79	21.1	9.2	32	S5(40%)	F	IP41 4:1
* SGL31-301P0-4	3000	1.0	Φ485	8×Φ10×16	39.0	1113	158	42.1	18.4	32	S5(40%)	F	IP41 4:1
* SGL31-300P5A-4	3000	0.5	Φ410	8×Φ10×16	20.0	941	93	24.8	9.2	32	S5(40%)	F	IP41 4:1
* SGL31-301P0A-4	3000	1.0	Φ410	8×Φ10×16	40.0	941	186	49.6	18.3	32	S5(40%)	F	IP41 4:1