

► SGL21A

Bezreduktorowa wciągarka linowa

Zasilanie : 380V
 Przełożenie : 2 : 1
 FZD12AB Hamulec : DC110V 2×1.0A
 Przybliżona masa własna : 285kg
 Maksymalne statyczne obciążenie wału : 3000kg

Nr kat.	Udźwig (kg)	Prędkość (m/s)	Średnica koła (mm)	Liny	Prąd (A)	Moment Obr. (Nm)	Obroty (rpm)	Częstość (Hz)	Moc (kW)	Bieguny Rating	INS.Class	IP Code
SGL21A-61P0A	630	1.0	Φ400	4×Φ10×16	9.7	389	96	25.6	3.9	32 S5(40%)	F	IP41
SGL21A-61P5A	630	1.5	Φ400	4×Φ10×16	14.9	420	144	38.4	6.3	32 S5(40%)	F	IP41
SGL21A-61P6A	630	1.6	Φ400	4×Φ10×16	14.9	420	153	40.8	6.7	32 S5(40%)	F	IP41
SGL21A-61P7A	630	1.75	Φ400	4×Φ10×16	15.9	420	167	44.5	7.3	32 S5(40%)	F	IP41
SGL21A-62P0A	630	2.0	Φ400	4×Φ10×16	18.3	420	192	51.2	8.4	32 S5(40%)	F	IP41
SGL21A-81P0A	800	1.0	Φ400	5×Φ10×16	12.1	502	96	25.6	5.0	32 S5(40%)	F	IP41
SGL21A-81P5A	800	1.5	Φ400	5×Φ10×16	18.8	530	144	38.4	8.0	32 S5(40%)	F	IP41
SGL21A-81P6A	800	1.6	Φ400	5×Φ10×16	18.8	530	153	40.8	8.5	32 S5(40%)	F	IP41
SGL21A-81P7A	800	1.75	Φ400	5×Φ10×16	20.7	530	167	44.5	9.3	32 S5(40%)	F	IP41
SGL21A-100P0A	1050	0.5	Φ400	5×Φ10×16	8.3	650	48	12.8	3.3	32 S5(40%)	F	IP41
SGL21A-101P0A	1050	1.0	Φ400	5×Φ10×16	14.7	604	96	25.6	6.1	32 S5(40%)	F	IP41
SGL21A-101P5A	1050	1.5	Φ400	5×Φ10×16	22.9	650	144	38.4	9.8	32 S5(40%)	F	IP41
SGL21A-101P6A	1050	1.6	Φ400	5×Φ10×16	22.9	650	153	40.8	10.4	32 S5(40%)	F	IP41
SGL21A-101P7A	1050	1.75	Φ400	5×Φ10×16	25.1	650	167	44.5	11.4	32 S5(40%)	F	IP41
SGL21A-102P0A	1050	2.0	Φ400	5×Φ10×16	28.2	650	192	51.2	13.1	32 S5(40%)	F	IP41

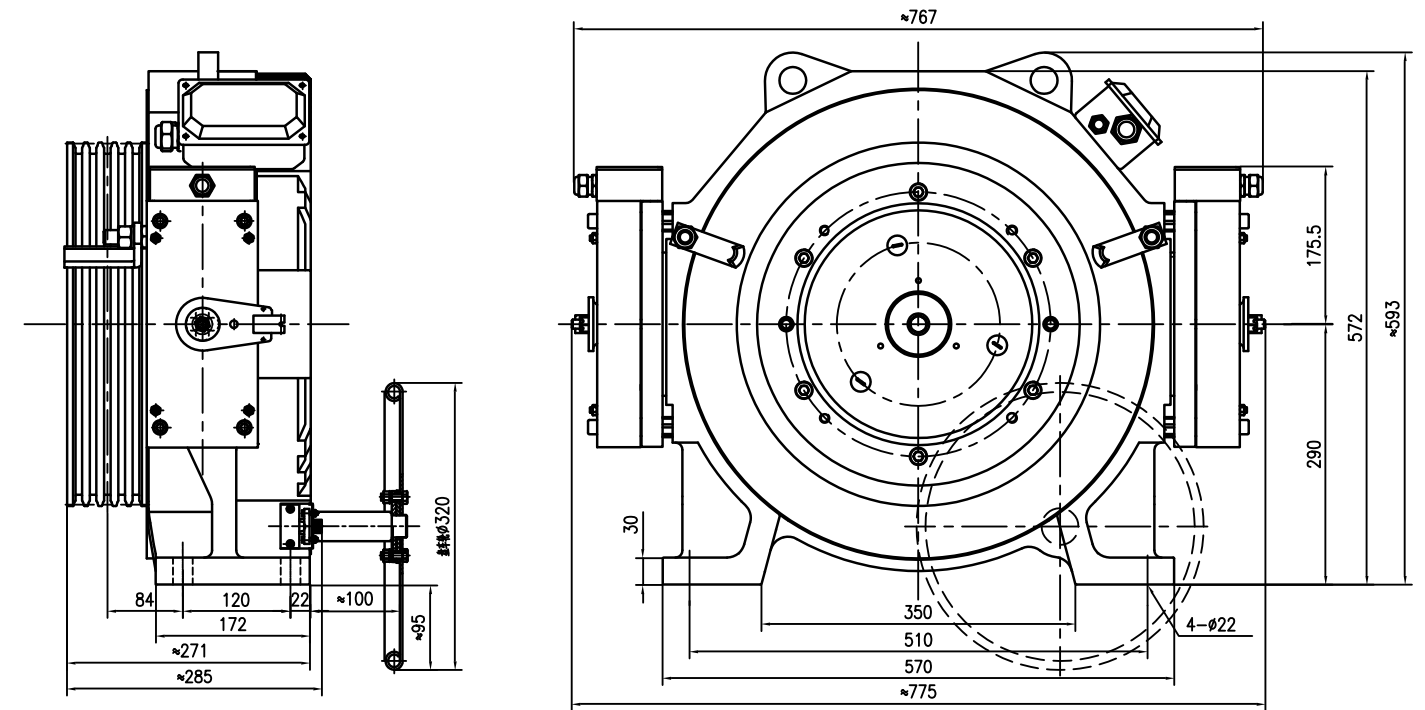

Uwagi:

Maszyna może być wyposażona w zdalne zwalnianie hamulca (4m)